

PLASTIC LAMINATE TUBES

First Aluminium's Plastic Laminate Tube was introduced when the preferred packaging material for fast moving products like toothpaste was changed worldwide from Aluminium to Plastic Laminate.

Laminate offers numerous advantages as a packaging material for cosmetic and medical creams and pastes. Aluminium Barrier Laminate (ABL) provides an equal protection to the product, as does an Aluminium tube, while offering a clear, large surface area for multi-colour printing. The tube remains highly flexible during its entire time of usage, keeping a good branded image.

- no reaction with content
- lightweight
- no sharp corners or edges
- smooth & hygienic finish
- wide printing options
- no exposure to moisture
- no cracking, no chipping
- no special coating needed
- preserves essential oils and perfumes



ABL laminate is made of different layers of polyethylene and a barrier layer of Aluminium foil. The example below shows an ABL laminate from Huhtamaki, Germany, suitable for surface printing:

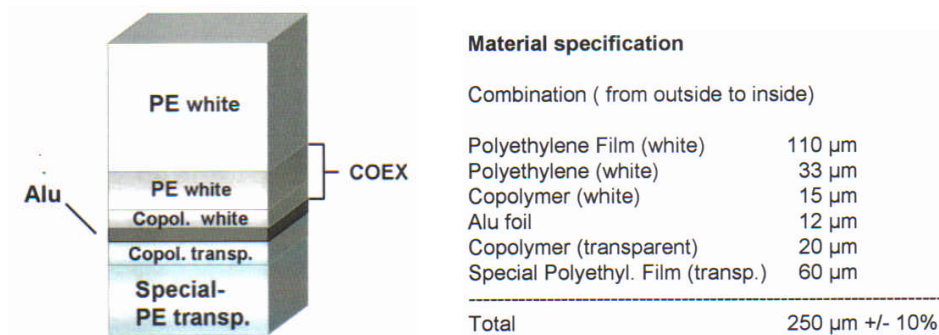

During the manufacturing process the laminate web is wrapped around a mandrel to form a tube and gets sealed. The layers are welded together to make a strong bond, while the overlapped barrier layer provides maximum protection to the tube content. The tube shoulder, made of high density polyethylene (HDPE), is compression moulded and bonded to the laminate tube in one step to provide a connection beyond the tensile strength of the used materials.

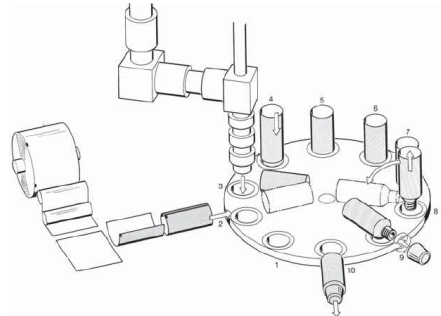
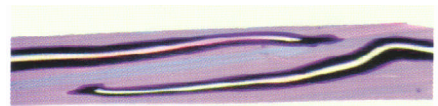

For more detailed information please contact our Sales Department by

- E-Mail: packsales@firstaluminium.net
- Phone: (234) (01) 492 2172/3
- Fax: (234) (01) 492 4836



ARTWORK FOR PLASTIC LAMINATE TUBES

Tube dia. available	: 22, 25, 32 & 35mm
Tube body thickness	: 225 - 275•
Tube length	: between 90mm to 190mm
Tube orifice	: 7.5mm *
Thread type	: S13 *
Cap/closure style	: Conical screw cap *
Cap/closure colour	: normally white, any other colour to match your needs
Printing	: Up to 6 colours (normal)
Varnish	: Glossy or Matt
Available options	: 5-stripe insert
* any other size or design is subject to price and volume	

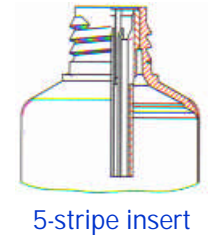
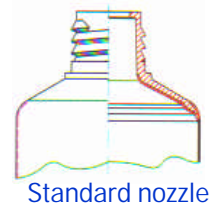

Being West Africa's largest tube manufacturer, First Aluminium Nigeria Plc. – Packaging Division offers its Customers the complete service of artwork development, laminate ordering and shipping, tube manufacturing and delivery to the customer's premises. Manufacturing equipment made in Switzerland guarantees high quality standards and efficient production of various tube diameters and lengths.

Available sizes:

Ø Tube [mm]	Approx. body length of Tube [mm]							
	85	100	115					
22								
25			80	114	135			
32				83	97	111	132	168
35					90	100	117	150
Content [ml]	20	25	30	40	50	60	75	100



Artwork layout dimension chart

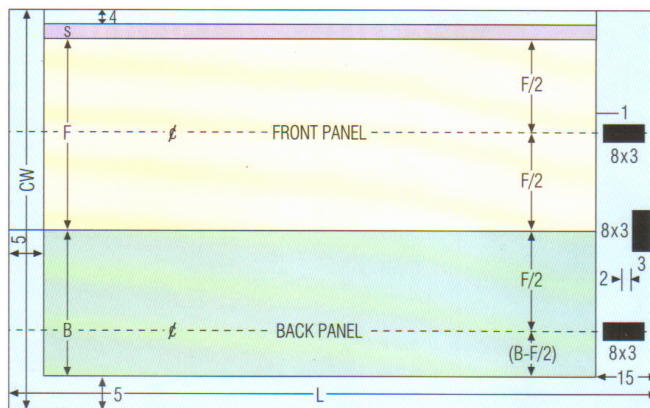

Use only front and back panel area for artwork design.

For better quality print, prepare artwork in the following sizes:

- Ø22 & 25mm: 2 x enlarged
- Ø32 & 35mm: 1.5 x enlarged

	F	B	S	CW
22 mm	33.6	25.6	3	71.2
25 mm	37.9	29.9	3	79.8
32 mm	50	39.1	5	103.1
35 mm	53.8	42.8	5	110.6

Note: all dimensions are in mm.

L = Tube length (from shoulder) minus 2mm

F = Front panel width

B = Back panel width

S = Side seam position

CW = Circumference width

